

REMOVAL AND INSTALLATION

Instrument Panel

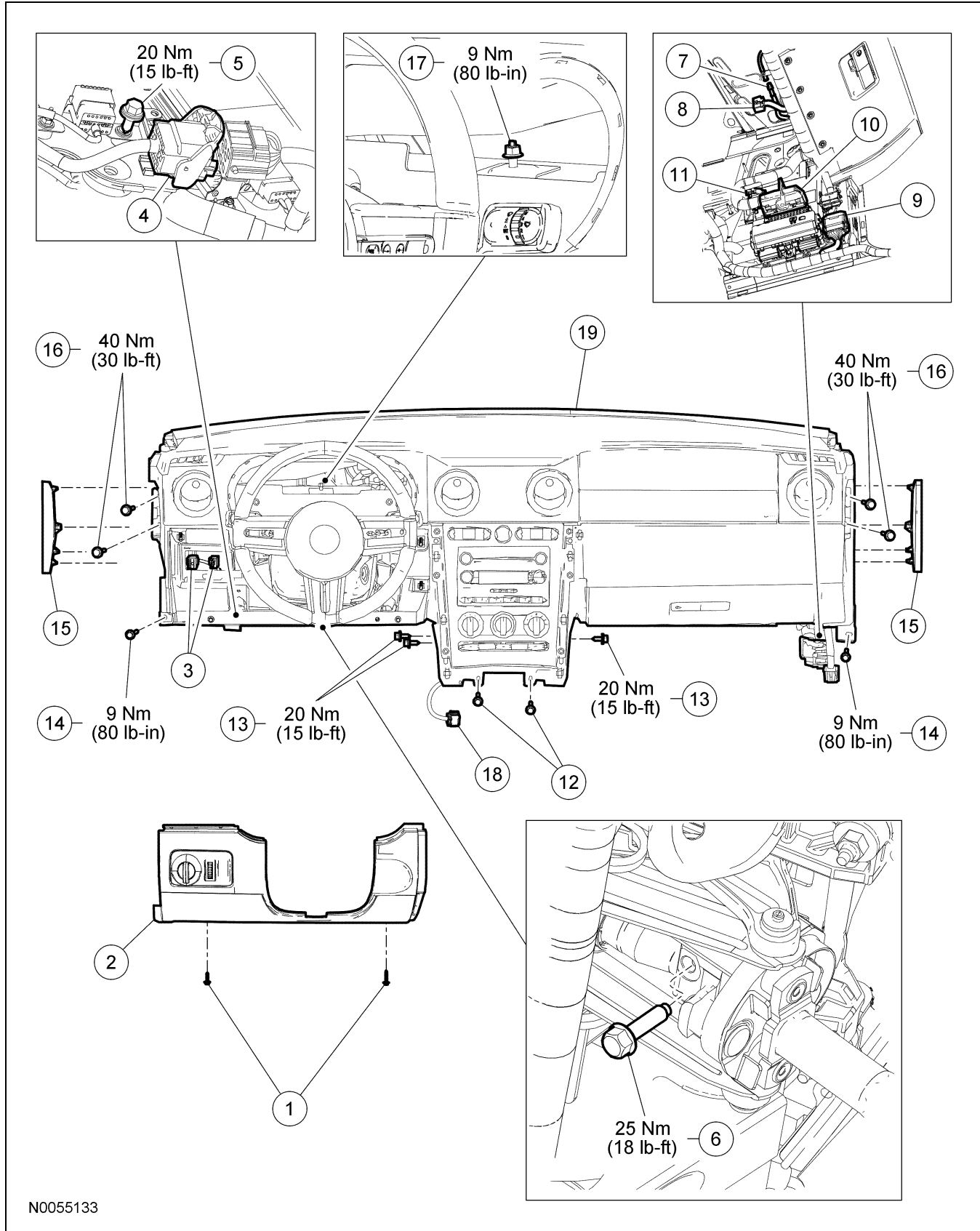



N0055133

REMOVAL AND INSTALLATION (Continued)

Item	Part Number	Description
1	W505156	Steering column reinforcement cover screws (2 required)
2	6304459	Steering column reinforcement cover
3	—	Headlamp switch electrical connectors (2 required) (part of 14401)
4	—	Bulkhead electrical connector (part of 14401)
5	W711097	Instrument panel support bolt
6	W704980	Steering column shaft bolt
7	19A136	Antenna connector
8	—	Defrost mode actuator electrical connector (part of 14401)
9	—	Bulkhead electrical connector (part of 14401)
10	—	Smart junction box (SJB) electrical connector (part of 14401)
11	—	SJB electrical connector (part of 14401)
12	W711564	Instrument panel center support screws (2 required)
13	W711097	Instrument panel center support bolts (3 required)
14	18C298	Instrument panel lower support bolts (2 required)
15	6304481/ 6304480	Instrument panel end panels (2 required)
16	W711097	Instrument panel upper support bolts (4 required)
17	N811309	Instrument panel cowl top bracket nut
18	—	Restraints control module (RCM) small connector (part of 14401)
19	6304304	Instrument panel

Removal and Installation

 **CAUTION: Electronic modules are sensitive to static electrical charges. If exposed to these charges, damage may result.**

- Depower the supplemental restraint system (SRS). For additional information, refer to Section 501-20B.
- Remove the floor console. For additional information, refer to Console — Floor in this section.
- Remove the 2 scuff plates.
- Remove the 2 A-pillar lower trim panels.
- NOTE:** On the coupe, install the front locating hook, then snap the A-pillar trim panel in place working rearward.
Remove the 2 A-pillar trim panels.
- Remove the instrument cluster. For additional information, refer to Section 413-01.
-  **CAUTION: Do not allow the steering column to rotate while the steering column shaft is disconnected or damage to the clockspring can result. If there is evidence that the steering column shaft has rotated, the clockspring must be removed and recentered. For additional information, refer to Section 501-20B.**
Secure the steering wheel, remove and discard the bolt, and separate the steering column shaft from the steering column.
 - To install, tighten to 25 Nm (18 lb-ft).
- Remove the 2 screws and the steering column reinforcement cover.
 - Disconnect the 2 electrical connectors
- On the LH side disconnect the instrument panel bulkhead electrical connector and remove the instrument panel support bolt.
 - To install, tighten to 20 Nm (15 lb-ft).
- On the RH side disconnect the antenna in-line connector and the 4 instrument panel harness electrical connectors.
- Remove the 2 instrument panel center support screws.
- Remove the 3 instrument panel center support bolts.
 - To install, tighten to 20 Nm (15 lb-ft).

REMOVAL AND INSTALLATION (Continued)

13. Through the instrument cluster opening, loosen the instrument panel cowl top bracket nut.
 - Tighten to 9 Nm (80 lb-in).
 14. Remove the 2 instrument panel lower support bolts.
 - To install, tighten to 9 Nm (80 lb-in).
 15. Remove the 2 instrument panel end panels.
 16. Remove the 4 instrument panel upper support bolts.
 - To install, tighten to 40 Nm (30 lb-ft).
 17. Disconnect the RCM small connector.
 18. **NOTE:** Two technicians are necessary to carry out this step.
Remove the instrument panel.
 19. To install, reverse the removal procedure.
-